

Eclipse EM102 Digital Manometer

The EM102 is a hand held pressure meter for various pressure measurements in industrial processes, combustion equipment, and laboratories. It has both static and differential pressure capabilities for applications such as draft pressure in exhaust flues, static pressure in combustion chambers, ovens or furnaces, and differential pressure across orifices for flow measurements.

Feature and Feature Description:

- Dual Display

The display shows the measurement value and units, maximum, minimum, data hold, and battery level.

- Hold Function

The measurement can be held on the display allowing the operator to look elsewhere at an event corresponding to the reading.

- Selectable Units

An operator can get the readings on the display to match those in the equipment documentation manuals so that he does not have to waste time with a calculator on each measurement.

- Piezo-Resistive Sensor

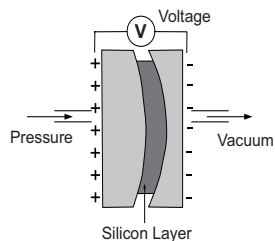

This digital manometer achieves stable, quick responding, repeatable and precise measurements by using an advanced piezo-resistive sensor. Integrating the sensor and circuits together allows a tighter accuracy specification based on the reading value instead of the full scale value. The Piezo-Resistive sensor is a diaphragm formed on a silicon substrate, which bends with applied pressure and generates millivoltage or millicurrent proportional to the pressure applied.

- Minimum and Maximum Values

The readings can be analyzed for lowest and highest value to assist troubleshooting and to determine process performance.

- Ergonomic Design

The housing is ergonomically designed for one-hand operation and the five keys simplify use of the multiple functions.

- Transportation Case

Soft vinyl zippered case. Foam coated interior for protection. Extra space for transportation of accessories.

- Pressure Connectors

This manometer comes with 2 clear tubes, 1 meter long, with a 4mm inner diameter and a 6mm outer diameter.



Specifications

Range	0-200 "w.c. (0 to \pm 500 mbar)
Alt Units	inWg, mbar, kPa, mmHg, PSI
Resolution	0.01 "w.c.; 0.1 mbar; 0.01 kPa; 0.1 mmHG; 0.001 PSI
Accuracy	\pm 0.5% rdg \pm 0,5 mbar
Max Pressure	20 psi / 1,4 mbar
Display	2-line, 5 digits, LCD
Keypad	Metal-coated with 5 keys
Operating Temperature	0 to 122°F (-18°F to 50°C)
Storage Temperature	-4 to 176°F (-20 to 80°C)
Connections	Barb and Compression Nut for 4mm ID, 6mm OD Tube
Power	9V Battery
Housing	Shock Proof, made of ABS, IP54 protection
Weight	6.7oz (190g)
Agency	EMC to EN61326-1
Zero	Push Button Zero
Min/Max	Yes
Hold Reading	Yes
Auto Shut Off	Adjustable from 0 to 120 min
Language	English

Dimensions (mm)

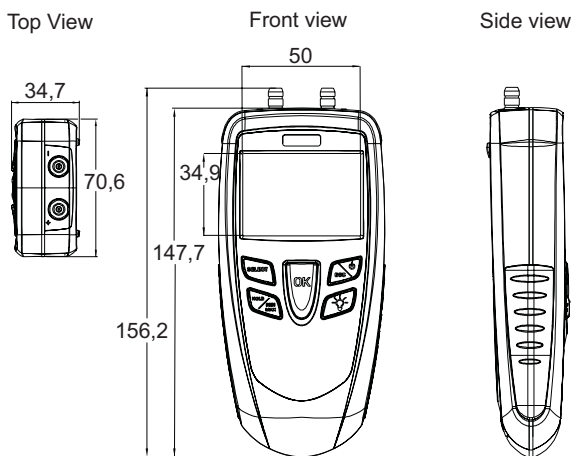



Offered By:

Power Equipment Company
2011 Williamsburg Road
Richmond, Virginia 23231
Phone (804) 236-3800
Fax (804) 236-3882

www.peconet.com